

# TB 9-6625-2339-35

CHANGE 3

DEPARTMENT OF THE ARMY TECHNICAL BULLETIN

## CALIBRATION PROCEDURE FOR SPECTRUM ANALYZER AN/USM-677 (AGILENT, MODEL E4407B)

Headquarters, Department of the Army, Washington, DC  
9 September 2004

*Distribution Statement A: Approved for public release; distribution is unlimited.*

TB 9-6625-2339-35, 22 September 2003, is changed as follows:

1. Remove old pages and insert new pages as indicated below. New or changed material is indicated by a vertical bar in the margin of the page.

### Remove Pages

11 and 12  
15 and 16  
21 and 22  
25 and 26  
27 and 28

### Insert Pages

11 and 12  
15 and 16  
21 and 22  
25 and 26  
27 and 28

2. File this change sheet in front of the publication for reference purposes.

**By Order of the Secretary of the Army:**

Official:

  
**JOEL B. HUDSON**

*Administrative Assistant to the  
Secretary of the Army*

0419503

**PETER J. SCHOOMAKER**

*General, United States Army  
Chief of Staff*

Distribution:

To be distributed in accordance with IDN 344787 requirements for TB 9-6625-2339-35.

# TB 9-6625-2339-35

CHANGE 2

DEPARTMENT OF THE ARMY TECHNICAL BULLETIN

## CALIBRATION PROCEDURE FOR SPECTRUM ANALYZER AN/USM-677 (AGILENT, MODEL E4407B)

Headquarters, Department of the Army, Washington, DC  
22 June 2004

*Distribution Statement A: Approved for public release; distribution is unlimited.*

TB 9-6625-2339-35, 22 September 2003, is changed as follows:

1. Remove old pages and insert new pages as indicated below. New or changed material is indicated by a vertical bar in the margin of the page.

### Remove Pages

1 and 2  
3 and 4  
5 and 6  
7 and 8  
11 and 12  
17 and 18  
19 and 20  
21 and 22  
23 and 24  
27 and 28

### Insert Pages

1 and 2  
3 and 4  
5 and 6  
7 and 8  
11 and 12  
17 and 18  
19 and 20  
21 and 22  
23 and 24  
27 and 28

2. File this change sheet in front of the publication for reference purposes.

**By Order of the Secretary of the Army:**

Official:

  
**JOEL B. HUDSON**

*Administrative Assistant to the  
Secretary of the Army*

0411702

**PETER J. SCHOOMAKER**

*General, United States Army  
Chief of Staff*

Distribution:

To be distributed in accordance with IDN 344787 requirements for TB 9-6625-2339-35.

# TB 9-6625-2339-35

CHANGE 1

DEPARTMENT OF THE ARMY TECHNICAL BULLETIN

---

## CALIBRATION PROCEDURE FOR SPECTRUM ANALYZER AN/USM-677 (AGILENT, MODEL E4407B)

---

Headquarters, Department of the Army, Washington, DC  
17 February 2004

---

*Distribution Statement A: Approved for public release; distribution is unlimited.*

---

TB 9-6625-2339-35, 22 September 2003, is changed as follows:

1. Remove old pages and insert new pages as indicated below. New or changed material is indicated by a vertical bar in the margin of the page.

**Remove Pages**

3 and 4  
11 and 12  
13 and 14

**Insert Pages**

3 and 4  
11 and 12  
13 and 14

2. File this change sheet in front of the publication for reference purposes.

**By Order of the Secretary of the Army:**

Official:



**JOEL B. HUDSON**

*Administrative Assistant to the  
Secretary of the Army*

**PETER J. SCHOOMAKER**  
*General, United States Army  
Chief of Staff*

0335101

Distribution:

To be distributed in accordance with IDN 344787, requirements for TB 9-6625-2339-35.



# TB 9-6625-2339-35

DEPARTMENT OF THE ARMY TECHNICAL BULLETIN

## CALIBRATION PROCEDURE FOR SPECTRUM ANALYZER

AN/USM-677

(AGILENT, MODEL E4407B)

Headquarters, Department of the Army, Washington, DC  
22 September 2003

*Distribution Statement A: Approved for public release; distribution is unlimited.*

### REPORTING OF ERRORS AND RECOMMENDING IMPROVEMENTS

You can improve this manual. If you find any mistakes or if you know of a way to improve these procedures, please let us know. Mail your letter or DA Form 2028 (Recommended Changes to Publications and Blank Forms) directly to: Commander, U.S. Army Aviation and Missile Command, ATTN: AMSAM-MMC-MA-NP, Redstone Arsenal, AL 35898-5000. A reply will be furnished to you. You may also provide DA Form 2028 information to AMCOM via e-mail, fax, or the World Wide Web. Our fax number is DSN 788-6546 or Commercial 256-842-6546. Our e-mail address is: [2028@redstone.army.mil](mailto:2028@redstone.army.mil). Instructions for sending an electronic 2028 may be found at the back of this manual. For the World Wide Web, use <https://amcom2028.redstone.army.mil>.

SECTION		Paragraph	Page
I.	IDENTIFICATION AND DESCRIPTION		
	Test instrument identification .....	1	2
	Forms, records, and reports .....	2	2
	Calibration description .....	3	2
II.	EQUIPMENT REQUIREMENTS		
	Equipment required .....	4	4
	Accessories required .....	5	4
III.	CALIBRATION PROCESS		
	Preliminary instructions.....	6	5
	Equipment Setup .....	7	5
	Frequency Readout and Marker Frequency Count Accuracy .....	8	6
	Frequency Span Readout Accuracy .....	9	9
	Noise Sidebands .....	10	10
	Residual FM .....	11	11
	Input Attenuator Accuracy .....	12	14
	Reference Level Accuracy .....	13	16

	<b>Paragraph</b>	<b>Page</b>
Resolution Bandwidth Switching Uncertainty .....	14	20
Absolute Amplitude Accuracy .....	15	21
Resolution Bandwidth Accuracy .....	16	23
Frequency Response.....	17	25
Displayed Average Noise .....	18	29
Residual Responses .....	19	32
Power Supply.....	20	33
Final Procedure .....	21	34

**SECTION I  
IDENTIFICATION AND DESCRIPTION**

**1. Test Instrument Identification.** This bulletin provides instructions for the calibration of Spectrum Analyzer, AN/USM-677 (Agilent, Model E4407B). The procurement specifications and manufacturer’s manual were used as the prime data sources in compiling these instructions. The equipment being calibrated will be referred to as the TI (test instrument) throughout this bulletin.

**a. Model Variations.** None

**b. Time and Technique.** The time required for this calibration is approximately 9 hours, using the dc and low frequency and microwave technique.

**2. Forms, Records, and Reports**

**a.** Forms, records, and reports required for calibration personnel at all levels are prescribed by TB 750-25.

**b.** Adjustments to be reported are designated (R) at the end of the sentence in which they appear. When adjustments are in tables, the (R) follows the designated adjustment. Report only those adjustments made and designated with (R)

**3. Calibration Description.** TI parameters and performance specifications which pertain to this calibration are listed in table 1.

Table 1. Calibration Description

Test instrument parameters	Performance specifications	
10 MHz Reference Accuracy	Frequency: 10 MHz Accuracy: $\pm 0.01$ ppm	
Resolution bandwidth accuracy and selectivity	Range: 100 Hz Accuracy: $< \pm 30\%$ Range: 300 Hz to 300 kHz Accuracy: $< \pm 10\%$ Range: 1 MHz and 2 MHz Accuracy: $< \pm 25\%$ Selectivity: 60 dB/3 dB bandwidth ratio: $< 15:1$	
Input attenuator accuracy	Range: 0 to 60 dB, referenced to 10 dB input attenuation Frequency range: 10 kHz to 22 GHz <sup>1</sup> Accuracy: $< \pm 1.8$ dB/10 dB step, 3.5 dB maximum	
IF gain uncertainty	Range: 0 to -80 dBm reference level, 10 dB input attenuation Accuracy: $< \pm 1.0$ dB	
Residual FM (zero span)	$< 5$ Hz X N p-p in 20 mS	
Noise sidebands	Range: 1.0 GHz, 0 dBm 10, 20, 30 and 100 kHz offset Accuracy: $< -90$ dBc @ 10 kHz offset $< -98$ dBc @ 20 kHz offset $< -100$ dBc @ 30 kHz offset $< -112$ dBc @ 100 kHz offset	
Frequency Readout Accuracy	Frequency range: 9 kHz to 26.5 GHz <sup>1</sup> Accuracy: $< \pm [0.5\% \text{ of span} + 15\% \text{ of resolution bandwidth} + 50 \text{ Hz} + (\text{center frequency} \times 0.0000001)]$	
Marker Frequency Count Accuracy	Frequency range: 9 kHz to 26.5 GHz <sup>1</sup> Accuracy: $< \pm [(\text{marker frequency} \times \text{reference frequency error}) + (50 \text{ Hz} \times N) + \text{LSD}]$	
Frequency Span Readout Accuracy	Range: 100 Hz to 1 GHz in a 1,2,5, sequence Accuracy $< \pm 5\%$ of the selected span over the center 80% of the graticule area	
Frequency response (10 dB input attenuation)	Frequency range: 10 kHz to 19.7 GHz <sup>1</sup> $< \pm 3.3$ dB	
Displayed average noise level (no signal at input, 100 Hz RES BW, and 0 dB input attenuation)	Frequency Range	(dBm)
	10 kHz	$< -90$
	100 kHz	$< -100$
	1 MHz to 2.9 GHz	$< -121$
	2.9 to 6.46 GHz	$< -121$
	6.46 to 13 GHz	$< -110$
13 to 19.7 GHz <sup>1</sup>	$< -105$	
19.7 to 22 GHz <sup>1</sup>	$< -100$	
Residual responses (no signal at input, 0 dB input attenuation)	Range: 200 kHz to 6.46 GHz Responses: $< -90$ dBm	
Frequency drift	$< 50$ Hz X N <sup>2</sup> per minute of sweep time spans $< 100$ kHz $< 2$ kHz X N <sup>2</sup> per minute of sweep time spans 101 kHz to $< 1$ MHz	

See footnotes at end of table.

Table 1. Calibration Description - Continued

Test instrument parameters	Performance specifications	
Marker amplitude accuracy	Measured at 300 MHz	
	Reference levels (dBm)	Accuracy (<math>\pm</math>dB)
	0	3.3
	-10	3.3
	-40	3.3
	-50	3.3

<sup>1</sup>Limited to 18.0 GHz due to N type input connector.

<sup>2</sup>N is the harmonic mixing mode.

## SECTION II EQUIPMENT REQUIREMENTS

**4. Equipment Required.** Table 2 identifies the specific equipment to be used in this calibration procedure. This equipment is issued with Secondary Transfer Calibration Standards Sets AN/GSM-287 and AN/GSM 705. Alternate items may be used by the calibrating activity. The items selected must be verified to perform satisfactorily prior to use and must bear evidence of current calibration. The equipment must meet or exceed the minimum use specifications listed in table 2. The accuracies listed in table 2 provide a four-to-one ratio between the standard and TI.

**5. Accessories Required.** The accessories required for this calibration are common usage accessories issued as indicated in 4 above and are not listed in this calibration procedure.

Table 2. Minimum Specifications of Equipment Required

Common name	Minimum use specifications	Manufacturer and model (part number)
ATTENUATOR (FIXED)	10 dB: Frequency range: 50 MHz to 18 GHz Accuracy: $\pm 0.3$ dB	Weinschel, Model 9918-10 dB (9918-( ) dB)
ATTENUATOR	Range: 0 to 12 dB Frequency: 50 MHz	Hewlett-Packard, Model 355C (7910807)
FUNCTION/ARBITRARY WAVEFORM GENERATOR	Frequency range: 50 MHz Amplitude: 0 dBm	Agilent, Model 33250A (33250A)
MEASURING RECEIVER	Frequency range: 300 MHz Accuracy: $\pm 300$ Hz dBm range: -9.7 to -10.3 Accuracy: $\pm 0.075$ dBm	Consisting of: Measuring Receiver Hewlett-Packard, Model 8902A (8902A) and Sensor Modules Hewlett-Packard, Models 11722A and 11792A (11722A) (911792A)
MULTIMETER	Range: 1000 Vdc Accuracy: $\pm 2$ Vdc	John Fluke, Model 8840A/AF (AN/GSM-64D)
SIGNAL GENERATOR	Frequency range: 10 MHz to 18 GHz Power range: 0 to -15 dBm Accuracy: $\pm 1.525$ dBm	Wiltron, Model 68369NV (68369NV)



Table 2. Minimum Specifications of Equipment Required - Continued

Common name	Minimum use specifications	Manufacturer and model (part number)
SYNTHESIZER/LEVEL GENERATOR	Frequency range: 10 kHz to 50 MHz Amplitude range: -80 to +12 dBm Accuracy: ±0.02 dB per 10 dB step	Hewlett-Packard, Model 3335AOPT001-KO6 (MIS-35938)
TIMER/COUNTER ANALYZER	Frequency range: 10 MHz Resolution: 0.001 Hz	Fluke, Model PM6681 (PM6681/656)

### SECTION III CALIBRATION PROCESS

#### 6. Preliminary Instructions

a. The instructions outlined in paragraphs 6 and 7 are preparatory to the calibration process. Personnel should become familiar with the entire bulletin before beginning the calibration.

b. Items of equipment used in this procedure are referenced within the text by common name as listed in table 2.

c. Unless otherwise specified, verify the result of each test and, whenever the test requirement is not met, take corrective action before continuing with the calibration. Additional maintenance information is contained in TM 43-6625-914-40.

d. When indications specified in paragraphs 8 through 19 are not within tolerance, perform the power supply check prior to making adjustments. After adjustments are made, repeat paragraphs 8 through 19. Do not perform power supply check if all other parameters are within tolerance.

e. Unless otherwise specified, all controls and control settings refer to TI.

#### 7. Equipment Setup

##### WARNING

HIGH VOLTAGE is used or exposed during the performance of this calibration. DEATH ON CONTACT may result if personnel fail to observe safety precautions. REDUCE OUTPUT(S) to minimum after each step within the performance check where applicable.

##### NOTE

The analyzer must sit with the power off for at least 60 minutes before performing the following test. This adequately simulates a cold start.

##### NOTE

Throughout this procedure soft keys are identified by the use of brackets [ ] around the key.

## TB 9-6625-2339-35

- a. Connect TI to 115 V ac power source.
- b. Connect equipment as shown in figure 1.

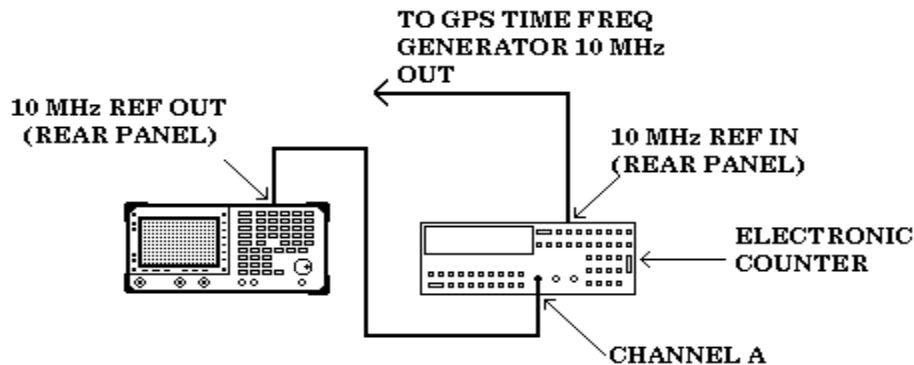

Figure 1. Frequency reference setup.

- c. Press **LINE** pushbutton to **ON** and record the power on time.
- d. Ensure TI is not in external reference mode.
- e. Set up electronic counter to measure frequency to 0.001 Hz resolution.
- f. Wait 5 minutes then record electronic counter reading to 0.001 Hz resolution as counter reading 1.
- g. Wait 10 more minutes then record electronic counter reading to 0.001 Hz resolution as counter reading 2.
- h. Wait 45 more minutes then record electronic counter reading to 0.001 Hz resolution as counter reading 3.
- i. Calculate the 5 minute warmup error (in ppm) by subtracting counter reading 3 from counter reading 1 and dividing the result by 10. The calculated value will be  $0 \pm 0.1$  ppm.
- j. Calculate the 15 minute warmup error (in ppm) by subtracting counter reading 3 from counter reading 2 and dividing the result by 10. The calculated value will be  $0 \pm 0.01$  ppm.
- k. If time base is out of tolerance perform (1) through (5) below:
  - (1) Press **System** key.
  - (2) Press **[Alignments]**.
  - (3) Press **[Timebase]**.
  - (4) Press **[Course]** or **[Fine]** as needed.
  - (5) Press <Return key three times when finished.

## 8. Frequency Readout and Marker Frequency Count Accuracy

### a. Performance Check

- (1) Connect TI **10 MHz REF OUT** to signal generator **10 MHz REF IN**.
- (2) Connect signal generator **RF Output** to TI **INPUT 50  $\Omega$** .
- (3) Set signal generator frequency to 1.5 GHz and level output to -10 dBm.
- (4) Press TI keys and enter values as listed in (a) through (f) below:

- (a) Preset.
- (b) **Factory Preset** softkey if it is displayed.
- (c) **Sweep, [Points 401]**.
- (d) **FREQUENCY, 1.5, [GHz]**.
- (e) **SPAN, 20, [MHz]**.
- (f) **Peak Search**.

(5) TI **Mkr1** frequency indication will be within the limits specified in the first row of table 3.

(6) Repeat technique of (4) (e) and (f) above for remaining TI settings listed in table 3. TI **Mkr1** frequency indications will be within the limits specified in table 3.

Table 3. Frequency Readout Accuracy @ 1.5 GHz

Signal generator Frequency setting (GHz)	Test instrument			
	FREQUENCY (GHz)	SPAN (MHz)	Mkr1 frequency indications (GHz)	
			Min	Max
1.5	1.5	20	1.49988	1.50012
1.5	1.5	10	1.49993	1.50007
1.5	1.5	1	1.499993	1.500007

(7) Set signal generator frequency to 4 GHz.

(8) Press TI keys and enter values using **DATA** keys as listed in (a) through (c) below:

- (a) **FREQUENCY, 4, [GHz]**.
- (b) **SPAN, 20, [MHz]**.
- (c) **Peak Search**.

(9) TI **Mkr1** frequency indication will be within the limits specified in the first row of table 4.

(10) Repeat technique of (8) (b) and (c) above for remaining TI settings listed in table 4. TI **Mkr1** frequency indications will be within the limits specified in table 4.

Table 4. Frequency Readout Accuracy @ 4 GHz

Signal generator Frequency setting (GHz)	Test instrument			
	FREQUENCY (CENTER FREQ) (GHz)	SPAN (MHz)	Mkr1 frequency indications (GHz)	
			Min	Max
4	4	20 MHz	3.99988	4.00012
4	4	10 MHz	3.99993	4.00007
4	4	1 MHz	3.999993	4.000007

(11) Set signal generator frequency to 9 GHz.

(12) Press TI keys and enter values as listed in (a) through (c) below:

- (a) **FREQUENCY, 9, [GHz]**.
- (b) **SPAN, 20, [MHz]**

**TB 9-6625-2339-35**

(c) **Peak Search.**

(13) TI **Mkr1** frequency indication will be within limits specified in first row of table 5.

(14) Repeat technique of (12) (b) and (c) above for remaining TI settings listed in table 5. TI **Mkr1** frequency indications will be within the limits specified in table 5.

Table 5. Frequency Readout Accuracy @ 9 GHz

Signal generator	Test instrument			
Frequency setting (GHz)	FREQUENCY (CENTER FREQ) (GHz)	SPAN (MHz)	Mkr1 frequency indications (GHz)	
			Min	Max
9	9	20 MHz	8.99988	9.00012
9	9	10 MHz	8.99993	9.00007
9	9	1 MHz	8.999993	9.000007

(15) Set signal generator frequency to 16 GHz.

(16) Press TI keys and enter values as listed in (a) through (c) below:

(a) **FREQUENCY, 16, [GHz].**

(b) **SPAN, 20, [MHz].**

(c) **Peak Search.**

(17) TI **Mkr1** frequency indication will be within limits specified in first row of table 6.

(18) Repeat technique of (16) (b) and (c) above for remaining TI settings listed in table 6. TI **Mkr1** frequency indications will be within the limits specified in table 6.

Table 6. Frequency Readout Accuracy @ 16 GHz

Signal generator	Test instrument			
frequency setting (GHz)	FREQUENCY (CENTER FREQ) (GHz)	SPAN (MHz)	Mkr1 frequency indications (GHz)	
			Min	Max
16	16	20 MHz	15.99988	16.00012
16	16	10 MHz	15.99993	16.00007
16	16	1 MHz	15.999992	16.000008

(19) Set signal generator frequency to 1.5 GHz.

(20) Press TI keys and enter values as listed in (a) through (h) below:

(a) **Preset.**

(b) **Factory Preset** softkey if it is displayed.

(c) **Sweep, [Points 401].**

(d) **FREQUENCY, 1.5, [GHz].**

(e) **SPAN, 10, [MHz].**

(f) **BW/Avg, [Res BW], 100, [kHz] (Man).**

(g) **Freq Count, [Marker Count] (On).**

(h) **[Resolution (Man)].**

(21) Press **Peak Search** key, then wait for a count to be taken. TI **Cntr1** frequency indication will be within limits specified in first row of table 7.

Table 7. Frequency Count Marker Accuracy

Signal generator Frequency settings (GHz)	Test instrument			
	FREQUENCY (GHz)	SPAN (MHz)	Cntr 1 frequency indications (GHz)	
			Min	Max
1.5	1.5	10	1.499999	1.500001
1.5	1.5	1	1.499999	1.500001
4	4	1	3.999999	4.000001
4	4	10	3.999999	4.000001
9	9	10	8.999999	9.000001
9	9	1	8.999999	9.000001
16	16	1	15.999999	16.000001
16	16	10	15.999999	16.000001

(22) Repeat technique of (19) and (20) (d) and (e) above for signal generator and TI **FREQUENCY** settings listed in table 7. TI **Cntr1** frequency indication will be within limits specified in table 7.

(23) Set all outputs to minimum and disconnect equipment setup.

**b. Adjustments.** None.

**9. Frequency Span Readout Accuracy**

**a. Performance Check**

- (1) Connect TI **10 MHz REF OUT** to signal generator **10 MHz REF IN**.
- (2) Connect signal generator **RF Output** to TI **INPUT 50Ω**.
- (3) Press TI keys as listed in (a) through (d) below:
  - (a) **Preset**.
  - (b) **Factory Preset** softkey if it is displayed.
  - (c) **Sweep, [Points 401]**.
  - (d) **FREQUENCY, [Start Freq], 0, [Hz], [Stop Freq], 3, [GHz]**.
- (4) Set signal generator frequency to .300 GHz and level output to -10 dBm.
- (5) Press TI keys as listed in (a) through (c) below:
  - (a) **Single** wait for completion of sweep.
  - (b) **Peak Search**.
  - (c) **Marker, [Delta]**.
- (6) Set signal generator frequency to 2.700 GHz.
- (7) Press TI keys as listed in (a) through (b) below:
  - (a) **Single** wait for completion of sweep.
  - (b) **Peak Search**.
- (8) TI **Mkr1 Δ** indication will be within limits specified in first row of table 8.

Table 8. Frequency Span Readout Accuracy

Signal generator		Test instrument					
Frequency settings in (4) above	Frequency settings in (6) above	FREQUENCY start frequency		FREQUENCY stop frequency		Mkr1 Δ indications	
		Min	Max	Min	Max	Min	Max
300 MHz	2.7 GHz	0 Hz	3 GHz	2.370 GHz	2.430GHz		
20 MHz	100 MHz	10 MHz	110 MHz	79.0 MHz	81.0 MHz		
10.01 MHz	10.09 MHz	10 MHz	10.1 MHz	79.0 kHz	81.0 kHz		
810 MHz	890 MHz	800 MHz	900 MHz	79.0 MHz	81.0 MHz		
800.01 MHz	800.09 MHz	800 MHz	800.1 MHz	79.0 kHz	81.0 kHz		
1.410 GHz	1.490 GHz	1.4 GHz	1.5 GHz	79.0 MHz	81.0 MHz		
1.49901 GHz	1.49909GHz	1.499 GHz	1.4991GHz	79.0 kHz	81.0 kHz		

(9) Repeat technique of (3) (d) through (8) above for TI **Start, Stop** and signal generator frequency settings listed in table 8. TI **Mkr1 Δ** indications will be within limits specified in table 8.

(10) Set all outputs to minimum and disconnect equipment setup.

**b. Adjustments.** None

## 10. Noise Sidebands

### a. Performance Check

(1) Connect function/arbitrary waveform generator **Output** to TI **INPUT 50 Ω**.

(2) Set function/arbitrary waveform generator for an output frequency of 50 MHz at an output level of 0 dBm.

(3) Press TI keys and enter values as listed in (a) through (x) below:

- (a) **Preset.**
- (b) **Factory Preset** softkey if it is displayed.
- (c) **FREQUENCY, 50, [MHz].**
- (d) **Sweep, [Points 401].**
- (e) **SPAN, 1, [MHz].**
- (f) **AMPLITUDE, [Attenuation], 10, [dB] (Man).**
- (g) **AMPLITUDE, [More], [Y Axis Units] (or Amptd Units), [dBm].**
- (h) **Peak Search (or Search).**
- (i) **FREQUENCY, [Signal Track (On)].**
- (j) **SPAN, 50, [kHz].**
- (k) **BW/Avg, 1, [kHz].**
- (l) **[Video BW], 30, [Hz] (Man).**
- (m) **FREQUENCY, [Signal Track] (Off).**
- (n) **Sweep, [Sweep Time], 5, [s] (Man).**
- (o) **Single.** Wait for the completion of sweep.
- (p) **Peak Search (or Search).**

- (q) **Marker, [Delta]**.
- (r) **[More], [Function], [Marker Noise (or Noise)]**.
- (s) **Det/Demod, [Detector], [Sample]**.
- (t) **Amplitude, 10, [-dBm]**.
- (u) **FREQUENCY, [CF Step], 10, [kHz]**.
- (v) **[Center Freq], ↑**.
- (w) **SPAN, [Zero Span]**.
- (x) **Single**.

(4) Wait for completion of sweep. TI **Mkr1 Δ Noise** indication will be within limit specified in first row of table 9.

(5) Press TI keys as listed in (a) through (b) below:

- (a) **FREQUENCY, ↓, ↓**.
- (b) **Single**.

(6) Wait for completion of sweep. TI **Mkr1 Δ Noise** indication will be within limit specified in second row of table 9.

(7) Press TI **FREQUENCY, ↑** keys.

(8) Repeat steps (3) (u) through (3) (x) and (4) through (7) above for remaining center frequency step sizes listed in table 9. TI **Mkr1 Δ Noise** indications will be within limits specified in table 9.

Table 9. Noise Sidebands

Center Frequency step size	Mkr1 Δ Noise indication limit
10 kHz	≤-90 dB/Hz
-10 kHz	≤-90 dB/Hz
20 kHz	≤-98 dB/Hz
-20 kHz	≤-98 dB/Hz
30 kHz	≤-100 dB/Hz
-30 kHz	≤-100 dB/Hz
100 kHz	≤-112 dB/Hz
-100 kHz	≤-112 dB/Hz

(9) Set all outputs to minimum and disconnect equipment setup.

**b. Adjustments.** None

**11. Residual FM**

**a. Performance Check**

- (1) Connect signal generator **RF Output** to TI **INPUT 50Ω**.
- (2) Set signal generator frequency to 1.0 GHz and level output to -10 dBm.
- (3) Press TI keys and enter values listed in (a) through (n) below:
  - (a) **Preset**.
  - (b) **Factory Preset** softkey if it is displayed.
  - (c) **Sweep, [Points 401]**.

**TB 9-6625-2339-35**

- (d) **FREQUENCY**, [**Center Freq**], 1, [**GHz**].
  - (e) **SPAN**, 1, [**MHz**].
  - (f) **AMPLITUDE**, [**Ref Level**], 9, [**-dBm**].
  - (g) [**Scale/Div**], 2, [**dB**].
  - (h) **BW/Avg**, [**Res BW**], 1, [**kHz**].
  - (i) **Peak Search** (or **Search**)
  - (j) **SPAN**, [**Span Zoom**], 5, [**kHz**]. Wait for the SPAN 5 kHz message to appear.
  - (k) **Peak Search** (or **Search**), **Marker** →, [**Marker** →**Ref Lvl**], **Marker**, [**Off**].
  - (l) **Single**. Wait for sweep to finish.
  - (m) **Peak Search** (or **Search**).
  - (n) [**Meas Tools**], [**Delta**].
- (4) Adjust TI RPG knob ccw until the **Mkr1 Δ** amplitude indicates between -7.7 and -8.3 dB and press [**Delta**] key.
- (5) Adjust TI RPG knob ccw for a **Mkr1 Δ** indication between -3.7 and -4.3 dB.
- (6) Divide **Mkr1 Δ** frequency (in Hz) by **Mkr1 Δ** amplitude (in dB) to obtain slope of resolution bandwidth filter and record result.

EXAMPLE: If **Mkr1 Δ** frequency is 380 Hz and **Mkr1 Δ** amplitude is 3.92 dB  
then slope would be:  $380 \text{ Hz} \div 3.92 \text{ dB} = 96.94 \text{ Hz/dB}$

- (7) Press TI keys as listed in (a) through (d) below:
- (a) **Marker**, [**Off**].
  - (b) **Peak Search** (or **Search**).
  - (c) [**Meas Tools**].
  - (d) [**Delta**].
- (8) Adjust TI RPG knob ccw for a **Mkr1 Δ** indication between -10.3 and -9.7 dB.
- (9) Press TI keys and enter values listed in (a) through (g) below:
- (a) **Marker**, [**Normal**].
  - (b) **Marker**→, [**Mkr**→**CF**].
  - (c) **Single**.
  - (d) **BW/Avg**, [**Video BW**] (Man), 1, [**kHz**].
  - (e) **SPAN**, [**Zero Span**].
  - (f) **Sweep**, [**Sweep Time**], 100, [**ms**].
  - (g) **Single**.



**NOTE**

If displayed trace is not approximately 5 divisions below the reference level, press **Sweep, Sweep** (Cont) keys and then **FREQUENCY** key. Adjust the RPG knob to place displayed trace approximately 5 divisions below reference level. Press **Single**.

- (10) Press **Peak Search** (or **Search**) key then **[Pk-Pk Search]** key.
- (11) Record absolute value of **Mkr1 Δ** amplitude indication.
- (12) Multiply value recorded in (6) above by value recorded in (11) above. Result will be less than 100 Hz.
- (13) Press TI keys and enter values listed in (a) through (n) below:
  - (a) **Preset**.
  - (b) **Factory Preset** softkey if it is displayed.
  - (c) **Sweep, [Points 401]**.
  - (d) **FREQUENCY, [Center Freq], 1, [GHz]**.
  - (e) **SPAN, 1, [MHz]**.
  - (f) **AMPLITUDE, [Ref Level], 9, [-dBm]**.
  - (g) **[Scale/Div], 2, [dB]**.
  - (h) **Peak Search** (or **Search**).
  - (i) **SPAN, [Span Zoom], 5, [kHz]**. Wait for the SPAN 5 kHz message to appear.
  - (j) **BW/Avg, [Res BW], 10, [Hz] (Man)**.
  - (k) **SPAN, 100 [Hz]**.
  - (l) **Peak Search** (or **Search**), **Marker →, [Marker →Ref Lvl], Marker, [Off]**.
  - (m) **Peak Search** (or **Search**).
  - (n) **[Meas Tools], [Delta]**.
- (14) Adjust TI RPG knob ccw until the **Mkr1 Δ** amplitude indicates between -9.7 and -10.3 dB.
- (15) Press TI keys and enter values listed in (a) through (g) below:
  - (a) **Marker, [Normal]**.
  - (b) **Marker→, [Mkr→CF]**.
  - (c) **Single**.
  - (d) **BW/Avg, [Video BW], 10, [Hz] (Man)**.
  - (e) **SPAN, [Zero Span]**.
  - (f) **Sweep, [Sweep Time], 20, [ms]**.
  - (g) **Single**.

**NOTE**

If displayed trace is not approximately 5 divisions below the reference level, press **Sweep, Sweep (Cont)** key and then **FREQUENCY** key. Adjust the RPG knob to place displayed trace approximately 5 divisions below reference level. Press **Single**.

- (16) Press **Peak Search (or Search)** key then **[Pk-Pk Search]** key.
- (17) Record absolute value of **Mkr1 Δ** amplitude indication.
- (18) Multiply value recorded in (17) above by 0.426 Hz/dB. Result will be less than 2 Hz.
- (19) Set all outputs to minimum and disconnect equipment setup.

**b. Adjustments.** None

**12. Input Attenuator Accuracy**

**a. Performance Check**

- (1) Connect equipment as shown in figure 2.

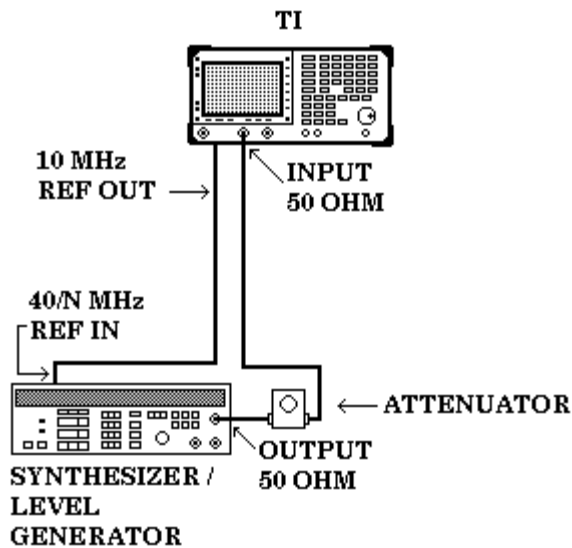

Figure 2. Input attenuator accuracy equipment setup.

- (2) Press synthesizer/level generator keys to values as listed in (a) and (b) below:
  - (a) **FREQUENCY** to **50 MHz**.
  - (b) **AMPLITUDE** to **-50 dBm**.
- (3) Press TI keys and enter values as listed in (a) through (k) below:
  - (a) **Preset**.
  - (b) **Factory Preset** softkey if it is displayed.
  - (c) **System, [Alignments], [Auto Align], [Off]**.

- (d) **Sweep, [Points 401].**
  - (e) **FREQUENCY, 50, [MHz].**
  - (f) **SPAN, 100, [kHz].**
  - (g) **AMPLITUDE, 55, [-dBm].**
  - (h) **AMPLITUDE, [Attenuation], 10, [dB].**
  - (i) **AMPLITUDE, [Scale/Div], 2, [dB].**
  - (j) **BW/Avg, 30, [kHz].**
  - (k) **BW/Avg, [Video BW], 100, [Hz].**
- (4) Set attenuator to 5 dB.
- (5) Adjust attenuator to position signal peak 2 to 3 divisions below TI reference level.
- (6) Press **TI Peak Search** (or **Search**), **Marker, [Delta]** keys.
- (7) Set signal generator to **-60 dBm**.
- (8) Press **TI AMPLITUDE, 65, [-dBm]** then **AMPLITUDE, [Attenuation], 0, [dB]**.
- (9) Press **TI Single**, then **Peak Search** (or **Search**). **TI Mkr1 Δ** indication will be within limits specified in first row of table 10.
- (10) Repeat (7) through (9) above for remaining synthesizer/level generator amplitude, **TI Ref Lvl** and **Atten** settings listed in table 10. **TI Mkr1 Δ** indication will be within limits specified in table 10.

Table 10. Input Attenuator Accuracy

Signal generator Amplitude settings (dBm)	Test instrument			
	Ref Lvl settings (dBm)	Atten settings (dB)	Mkr1 Δ indications (dB)	
			Min	Max
-60	-65	0	-10.3	-9.7
-55	-60	5	-5.3	-4.7
-45	-50	15	4.7	5.3
-40	-45	20	9.7	10.3
-35	-40	25	14.65	15.35
-30	-35	30	19.6	20.4
-25	-30	35	24.55	25.45
-20	-25	40	29.5	30.5
-15	-20	45	34.45	35.55
-10	-15	50	39.4	40.6
-5	-10	55	44.35	45.65
0	-5	60	49.3	50.7
5	0	65	54.25	55.75

- (11) Set all outputs to minimum and disconnect equipment setup.

**b. Adjustments.** None

### 13. Reference Level Accuracy

#### a. Performance Check

- (1) Connect equipment as shown in figure 3.

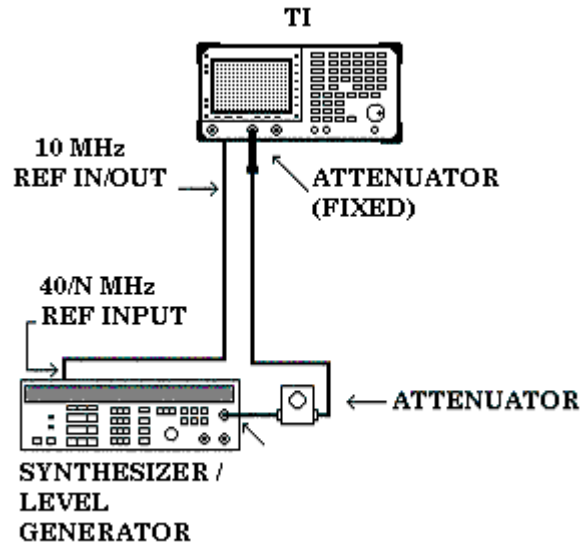

Figure 3. Reference level accuracy equipment setup.

- (2) Press synthesizer/level generator keys to values listed in (a) and (b) below:
- FREQUENCY** to **50 MHz**.
  - AMPLITUDE** to **+12 dBm**.
  - AMPTD INCR** to **10 +dBm**.
- (3) Press TI keys and enter values as listed in (a) through (k) below:
- Preset**.
  - Factory Preset** softkey if it is displayed.
  - System, Alignments, [Auto Align], [Off]**.
  - Sweep, [Points, 401]**.
  - FREQUENCY, 50, [MHz]**.
  - AMPLITUDE, 0, [dBm]**.
  - AMPLITUDE, [Attenuation], 10, [dB] (Man)**.
  - AMPLITUDE, [Scale/Div], 1, [dB]**.
  - SPAN, 50, [kHz]**.
  - BW/Avg, 3, [kHz]**.
  - BW/Avg, [Video BW], 30, [Hz]**.
- (4) Set attenuator No. 1 to 5 dB.

- (5) Adjust attenuator No. 1 to position signal peak 2 to 3 dB (2 to 3 divisions) below TI reference level.
- (6) Press TI keys as listed in (a) through (c) below:
  - (a) **Single**.
  - (b) **Peak Search** (or **Search**).
  - (c) **Marker, [Delta]**.
- (7) Press synthesizer/level generator **AMPLITUDE** key.
- (8) Press synthesizer/level generator **INCR ↓** key.
- (9) Press TI **AMPLITUDE, [Ref Lvl], 10, [-dBm]** keys.
- (10) Press TI **Single** key and wait for completion of sweep.
- (11) Press TI **Peak Search** (or **Search**) key.
- (12) TI **Mkr1 Δ** indication will be within limits specified in first row of table 11.
- (13) Repeat technique of (8) through (12) above for synthesizer/level generator amplitude and TI **Ref Lvl** settings listed in table 11. TI **Mkr1 Δ** indications will be within limits specified in table 11.

Table 11. Log Mode, Analog Bandwidths

Synthesizer/level generator	Test instrument			
	Amplitude settings (dBm)	Ref Lvl settings (dBm)	MKR1 Δ indications (dB)	
			Min	Max
+2	-10	-9.7	-10.3	
-8	-20	-19.7	-20.3	
-18	-30	-29.7	-30.3	
-28	-40	-39.7	-40.3	
-38	-50	-49.5	-50.5	
-48	-60	-59.5	-60.5	
-58	-70	-69.5	-70.5	
-68	-80	-79.3	-80.7	
-78	-90	-89.3	-90.7	

- (14) Set synthesizer/level generator amplitude to +12 dBm.
- (15) Press TI keys and enter values as listed in (a) through (g) below:
  - (a) **AMPLITUDE, 0, [dBm]**.
  - (b) **SPAN, 150, [Hz]**.
  - (c) **BW/Avg, 10, [Hz]**.
  - (d) **BW/Avg, [Video BW], 1, [Hz]**.
  - (e) **Single**.
  - (f) **Peak Search** (or **Search**).
  - (g) **Marker, [Delta]**.
- (16) Press synthesizer/level generator **AMPLITUDE** key.

**TB 9-6625-2339-35**

- (17) Press synthesizer/level generator **INCR** ↓ key.
- (18) Press TI **AMPLITUDE**, [**Ref Lvl**], **10**, [**-dBm**] keys.
- (19) Press TI **Single** key and wait for completion of sweep.
- (20) Press TI **Peak Search** (or **Search**) key.
- (21) TI **Mkr1 Δ** indication will be between -9.7 and -10.3 dB.

(22) Repeat technique of (17) through (21) above for synthesizer/level generator amplitude and TI **Ref Lvl** settings listed in table 12. TI **Mkr1 Δ** indications will be within limits specified in table 12.

Table 12. Log Mode, Digital Bandwidths

Synthesizer/level generator	Test instrument			
	Amplitude settings (dBm)	Ref Lvl settings (dBm)	Δ MKR indications (dB)	
			Min	Max
+2	-10	-9.7	-10.3	
-8	-20	-19.7	-20.3	
-18	-30	-29.7	-30.3	
-28	-40	-39.7	-40.3	
-38	-50	-49.5	-50.5	
-48	-60	-59.5	-60.5	
-58	-70	-69.5	-70.5	
-68	-80	-79.3	-80.7	
-78	-90	-89.3	-90.7	

- (23) Set synthesizer/level generator amplitude to +12 dBm .
- (24) Press TI keys and enter values as listed in (a) through (h) below:
  - (a) **AMPLITUDE**, **0**, [**dBm**].
  - (b) **AMPLITUDE**, [**Scale Type**] (lin).
  - (c) **AMPLITUDE**, [**More 1**] , [**Y axis Units**] (or **Amptd Units**), [**dBm**].
  - (d) **SPAN**, **50**, [**kHz**].
  - (e) **BW/Avg**, **3**, [**kHz**].
  - (f) **BW/Avg**, [**Video BW**], **30**, [**Hz**].
  - (g) **Sweep**, [**Sweep**] (Cont).
  - (h) **Marker**, [**Off**].

(25) Adjust attenuator to position signal peak 2 to 3 dB (2 to 3 divisions) below TI reference level.

- (26) Press TI keys as listed in (a) through (c) below:
  - (a) **Single**.
  - (b) **Peak Search** (or **Search**).
  - (c) **Marker**, [**Delta**].

(27) Press synthesizer/level generator **AMPLITUDE** key.

- (28) Press synthesizer/level generator **INCR** ↓ key.
- (29) Press TI **AMPLITUDE**, [**Ref Lvl**], **10**, [**-dBm**] keys.
- (30) Press TI **Single** key and wait for completion of sweep.
- (31) Press TI **Peak Search** (or **Search**) key.
- (32) TI **Mkr1 Δ** indication will be between -9.7 and -10.3 dB.
- (33) Repeat technique of (28) through (32) above for synthesizer/level generator amplitude and TI **Ref Lvl** settings listed in table 13. TI **Mkr1 Δ** indications will be within limits specified in table 13.

Table 13. Linear Mode, Analog Bandwidths

Synthesizer/level generator amplitude settings (dBm)	Test instrument		
	Ref Lvl settings (dBm)	MKR1 Δ indications (dB)	
		Min	Max
+2	-10	-9.7	-10.3
-8	-20	-19.7	-20.3
-18	-30	-29.7	-30.3
-28	-40	-39.7	-40.3
-38	-50	-49.5	-50.5
-48	-60	-59.5	-60.5
-58	-70	-69.5	-70.5
-68	-80	-79.3	-80.7
-78	-90	-89.3	-90.7

- (34) Set synthesizer/level generator amplitude to +12 dBm .
- (35) Press TI keys and enter values as listed in (a) though (g) below:
  - (a) **AMPLITUDE**, **0**, [**dBm**].
  - (b) **SPAN**, **150**, [**Hz**].
  - (c) **BW/Avg**, **10**, [**Hz**].
  - (d) **BW/Avg**, [**Video BW**], **1**, [**Hz**].
  - (e) **Single**.
  - (f) **Peak Search** (or **Search**).
  - (g) **Marker**, [**Delta**].
- (36) Press synthesizer/level generator **AMPLITUDE** key.
- (37) Press synthesizer/level generator **INCR** ↓ key.
- (38) Press TI **AMPLITUDE**, [**Ref Lvl**], **10**, [**-dBm**] keys.
- (39) Press TI **Single** key and wait for completion of sweep.
- (40) Press TI **Peak Search** (or **Search**) key.
- (41) TI **Mkr1 Δ** indication will be between -9.7 and -10.3 dB.
- (42) Repeat technique of (37) through (41) above for synthesizer/level generator amplitude and TI **Ref Lvl** settings listed in table 14. TI **Mkr1 Δ** indications will be within limits specified in table 14.

Table 14. Linear Mode, Digital Bandwidths

Synthesizer/level generator amplitude settings (dBm)	Test instrument		
	REF LVL settings (dBm)	MKR1 Δ indications (dB)	
		Min	Max
+2	-10	-9.7	-10.3
-8	-20	-19.7	-20.3
-18	-30	-29.7	-30.3
-28	-40	-39.7	-40.3
-38	-50	-49.5	-50.5
-48	-60	-59.5	-60.5
-58	-70	-69.5	-70.5
-68	-80	-79.3	-80.7
-78	-90	-89.3	-90.7

(43) Press TI keys as listed in (a) through (d) below:

- (a) **Preset.**
- (b) **System.**
- (c) **[Alignments].**
- (d) **[Auto Align], [All].**

(44) Set all outputs to minimum and disconnect equipment setup.

**b. Adjustments. None**

**14. Resolution Bandwidth Switching Uncertainty**

**a. Performance Check**

(1) Connect TI **AMPTD REF OUT** to **RF INPUT 50Ω**.

(2) Press TI keys and enter values as listed in (a) through (k) below:

- (a) **Preset.**
- (b) **Factory Preset** softkey if it is displayed.
- (c) **Sweep, [Points 401].**
- (d) **Input/Output** (or **Input**), **[Amptd Ref Out]** (On).
- (e) **FREQUENCY, 50, [MHz].**
- (f) **SPAN, 5, [kHz].**
- (g) **AMPLITUDE, [More], [Y Axis Units]** (or **Amptd Units**), **[dBm].**
- (h) **AMPLITUDE, 19, [-dBm].**
- (i) **AMPLITUDE, [Scale/Div], 1, [dB].**
- (j) **BW/Avg, [Res BW], 1, [kHz]** (Man).
- (k) **BW/Avg, [Video BW], 1, [kHz]** (Man).

(3) Press **AMPLITUDE** and adjust **RPG** knob to place the displayed signal 5 divisions below the reference level.

(4) Press TI keys as listed in (a) through (c) below:

- (a) **Peak Search** (or **Search**).
- (b) **Marker→, [Mkr→CF].**



- (c) **Marker, [Delta]**.
- (5) Set TI **RES BW** and **SPAN** for the first values listed in table 15.
- (6) Press TI keys as listed in (a) through (c) below:
  - (a) **Peak Search** (or **Search**).
  - (b) **Marker→, [Mkr→CF]**.
  - (c) **Peak Search** (or **Search**).
- (7) TI **Mkr1 Δ** indication will be within the limits specified in table 15 for the **RES BW** and **SPAN** settings under test.
- (8) Repeat technique of (5) through (7) above for the remaining **RES BW** and **SPAN** settings listed in table 15.

Table 15. Resolution Bandwidth Switching Uncertainty

Test instrument <sup>1</sup>			
RES BW	SPAN	Mkr1 Δ indication (dB)	
		Min	Max
3 kHz	10 kHz	-0.3	0.3
9 kHz	50 kHz	-0.3	0.3
10 kHz	50 kHz	-0.3	0.3
30 kHz	100 kHz	-0.3	0.3
100 kHz	500 kHz	-0.3	0.3
120 kHz	500 kHz	-0.3	0.3
300 kHz	1 MHz	-0.3	0.3
1 MHz	5 MHz	-0.3	0.3
3 MHz	10 MHz	-0.3	0.3
5 MHz	25 MHz	-0.6	0.6
300 Hz	1 kHz	-0.3	0.3
200 Hz	1 kHz	-0.3	0.3
100 Hz	500 Hz	-0.3	0.3
30 Hz	100 Hz	-0.3	0.3
10 Hz	100 Hz	-0.3	0.3

<sup>1</sup>Signal may need to be re-centered due to drift when using narrow frequency span settings.

- (9) Disconnect equipment setup.

**b. Adjustments.** None

**15. Absolute Amplitude Accuracy**

**a. Performance Check**

**NOTE**

If necessary, perform measuring receiver and sensor module ZERO and CALIBRATE.

- (1) Connect synthesizer/level generator **OUTPUT 50Ω** to measuring receiver power sensor.
- (2) Press synthesizer/level generator keys to values listed in (a) and (b) below:
  - (a) **FREQUENCY** to **50 MHz**.

**TB 9-6625-2339-35**

- (b) **AMPLITUDE** to **-20 dBm**.
- (3) Setup measuring receiver to measure power in dBm at 50 MHz.
- (4) Adjust synthesizer/level generator power level for a measuring receiver indication of -20 dBm.
- (5) Record measuring receiver indication in Actual power column of table 16 below.
- (6) Connect TI **AMPTD REF OUT** to **RF INPUT 50Ω**.
- (7) Press TI keys and enter values as listed in (a) through (l) below:
  - (a) **Preset**.
  - (b) **Factory Preset** softkey if it is displayed.
  - (c) **System, [Alignments]**.
  - (d) **[Align Now], [All]** (wait for alignment to finish).
  - (e) **◀Return, [Auto Align], [Off]**.
  - (f) **FREQUENCY, [Center Freq], 50, [MHz]**.
  - (g) **SPAN, 2 [kHz]**.
  - (h) **BW/Avg, [Res BW] (Man), 1, [kHz]**.
  - (i) **[Video BW Man], 1, [kHz]**.
  - (j) **Sweep, [Points 401], Enter**.
  - (k) **Amplitude, 20, [-dBm], [Attenuation] (Man), 10, [dB], [Scale Type] (Log)**.
  - (l) **Amplitude, [More], [Y Axis Units] (or Amptd Units), [Volts], Det/Demod, [Detector], [Sample], ▶Return**.
- (8) Disconnect synthesizer/level generator **OUTPUT 50Ω** from power sensor.
- (9) Disconnect TI **AMPTD REF OUT** from **RF INPUT 50Ω**.
- (10) Connect synthesizer/level generator **OUTPUT 50Ω** to TI **RF INPUT 50Ω**.
- (11) Press TI **Peak Search** (or **Search**) key.
- (12) Convert the marker amplitude reading (**Mkr1**) from volts to dBm using the following equation and record value in table 16.

$$50\Omega \text{ Input Marker Amptd (dBm)} = 10 \times \text{Log}(\text{Mkr (V}^2 / 0.05))$$
$$\text{Marker Amptd (dBm)} \text{ _____ dBm}$$

- (13) Subtract the measuring receiver reading recorded in step (5) above from the marker amptd calculated in step (12) above and record in table 16 as absolute amplitude accuracy (Log). Verify the difference recorded in table 16 is within the limits specified.
- (14) Press TI keys and enter values as listed in (a) through (b) below:
  - (a) **AMPLITUDE, [Scale Type] (Lin)**
  - (b) **Peak Search** (or **Search**)

(15) Convert the marker amplitude reading (**Mkr1**) from volts to dBm using the equation in step (12) above and record value in table 16.

(16) Subtract the measuring receiver reading recorded in step (5) above from the marker amptd calculated in step (15) above and record in table 16 as absolute amplitude accuracy (Lin). Verify the difference recorded in table 16 is between the limits specified.

Table 16. Absolute Amplitude Accuracy

Measuring Receiver	Test instrument		Converted marker amplitude (dB)	Absolute Amplitude Accuracy	Min (dB)	Max (dB)
	Mkr1 amplitude (volts)	Scale type		Accuracy = converted marker amplitude (dB) – measuring receiver reading (dB)		
Actual power (dB)		Log			-0.34	0.34
		Lin			-0.34	0.34

(17) Press TI keys and enter values as listed in (a) though (d) below:

- (a) **Preset.** Press the **Factory Preset** softkey if it is displayed.
- (b) **System.**
- (c) **[Alignments].**
- (d) **[Auto Align], [All].**

(18) Set all outputs to minimum and disconnect equipment setup.

**b. Adjustments.** None

**16. Resolution Bandwidth Accuracy**

**a. Performance Check**

(1) Connect TI **10 MHz Ref Out** to synthesizer/level generator **40/N MHz REF** and synthesizer/level generator **OUTPUT 50 Ω** to TI **RF INPUT 50 Ω**.

(2) Press synthesizer/level generator keys to values as listed in (a) and (b) below:

- (a) **FREQUENCY** to **50 MHz**.
- (b) **AMPLITUDE** to **-5 dBm**.

(3) Press TI keys and enter values as listed in (a) through (j) below:

- (a) **Preset.**
- (b) **Factory Preset** softkey if it is displayed.
- (c) **System, [Alignments], [Auto Align], [Off].**
- (d) **Sweep, [Points 401].**
- (e) **FREQUENCY, 50, [MHz].**
- (f) **SPAN, 7.5, [MHz].**
- (g) **AMPLITUDE, [Scale/Div], 1, [dB].**
- (h) **AMPLITUDE, [Y Axis Units] (or Amptd Units), [dBm].**
- (i) **BW/Avg, 5, [MHz].**
- (j) **BW/Avg, [Video BW], 30, [Hz].**

(4) Press TI **Peak Search** (or **Search**), **[Meas Tools], [Mkr → CF].**

**TB 9-6625-2339-35**

- (5) Adjust synthesizer/level generator amplitude to position the signal for a marker amplitude reading of -5 dBm +/- 0.2 dB.
- (7) Set synthesizer/level generator **AMPTD INCR** to **3 dB**.
- (8) Press TI **Peak Search** (or **Search**), **Marker**, [**Delta**].
- (9) Press synthesizer/level generator **AMPLITUDE** key then **INCR** ↑ key.
- (10) Press TI **Marker** key, then lower the marker frequency by adjusting the RPG knob (ccw) until the marker delta amplitude is 0 +/- 0.05 dB.
- (11) Record the marker frequency readout as the lower 3 db frequency in table 17.
- (12) Raise the TI marker frequency by adjusting the RPG knob (cw) until the marker delta amplitude is 0 +/- 0.05 dB.
- (13) Record the marker frequency readout as the upper 3 db frequency in table 17.
- (14) Subtract the lower 3 dB frequency recorded in (11) above from the upper 3 dB frequency recorded in (13) above. The result will be within the limits specified in table 17.
- (15) Press synthesizer/level generator **AMPLITUDE** key.
- (16) Press synthesizer/level generator **INCR** ↓ key.
- (17) Press TI **Marker**, [**Normal**] keys.
- (18) Repeat technique of (4) through (17) above for the TI **BW** and **SPAN** settings listed in table 17. TI **Mkr1 Δ** indications will be within limits specified in table 17.

Table 17. 3 dB Resolution Bandwidth Accuracy

Test instrument					
SPAN settings	BW settings	Mkr1 Δ indications			
		MHz			
MHz	MHz	Lower marker frequency	Upper marker frequency	Min MHz	Max MHz
7.5	5			3.5	6.5
4.5	3			2.55	3.45
1.5	1			0.85	1.15
.450	.300			0.255	0.345
.150	.100			0.085	0.115
.045	.030			0.0255	0.0345
.015	.010			0.0085	0.0115
.0045	.003			0.00255	0.00345
.0015	.001			0.00085	0.00115

- (19) Set synthesizer/level generator **AMPLITUDE** to **-7 dBm**.
- (20) Press TI keys and enter values as listed in (a) and (b) below:
  - (a) **BW/Avg, 120, [kHz]**.
  - (b) **SPAN, 180, [kHz]**.
- (21) Press TI **Peak Search** (or **Search**), [**Meas Tools**], [**Mkr → CF**].
- (22) Adjust synthesizer/level generator amplitude to position the signal for a marker amplitude reading of -7 dBm +/- 0.2 dB.

- (23) Set synthesizer/level generator **AMPTD INCR** to **6 dB**.
- (24) Press TI **Peak Search** (or **Search**), **Marker**, [**Delta**] keys.
- (25) Press synthesizer/level generator **AMPLITUDE** key then **INCR** ↑ key.
- (26) Press TI **Marker** key. Then lower the marker frequency by adjusting the RPG knob (ccw) until the marker delta amplitude is 0 +/- 0.05 dB.
- (27) Record the marker frequency readout as the lower 6 db frequency in table 18.
- (28) Raise the TI marker frequency by adjusting the RPG knob (cw) until the marker delta amplitude is 0 +/- 0.05 dB.
- (29) Record the marker frequency readout as the upper 6 db frequency in table 18.
- (30) Subtract the lower 6 dB frequency recorded in (27) above from the upper 3 dB frequency recorded in (29) above. The result will be within the limits specified in table 18.
- (31) Press synthesizer/level generator **AMPLITUDE** key.
- (32) Press synthesizer/level generator **INCR** ↓ key.
- (33) Press TI **Marker**, [**Off**] keys.
- (34) Repeat technique of (21) through (33) above for the TI **BW** and **SPAN** settings listed in table 18. TI **Mkr1 Δ** indications will be within limits specified in table 18.

Table 18. 6 dB Resolution Bandwidth Accuracy

Test instrument					
SPAN settings kHz	BW settings kHz	Δ Mkr1 indications MHz			
		Lower marker frequency	Upper marker frequency	Min kHz	Max kHz
180	120			102	138
13.5	9			7.65	10.35

- (35) Press TI keys and enter values as listed in (a) though (d) below:
  - (a) **Preset** (**Factory Preset** softkey if it is displayed).
  - (b) **System**.
  - (c) [**Alignments**].
  - (d) [**Auto Align**], [**All**].
- (36) Set all outputs to minimum and disconnect equipment setup.
  - a. **Adjustments**. None

**17. Frequency Response**

**a. Performance Check**

**NOTE**

If necessary, perform measuring receiver and sensor module ZERO and CALIBRATE.

- (1) Connect equipment as shown in figure 4.

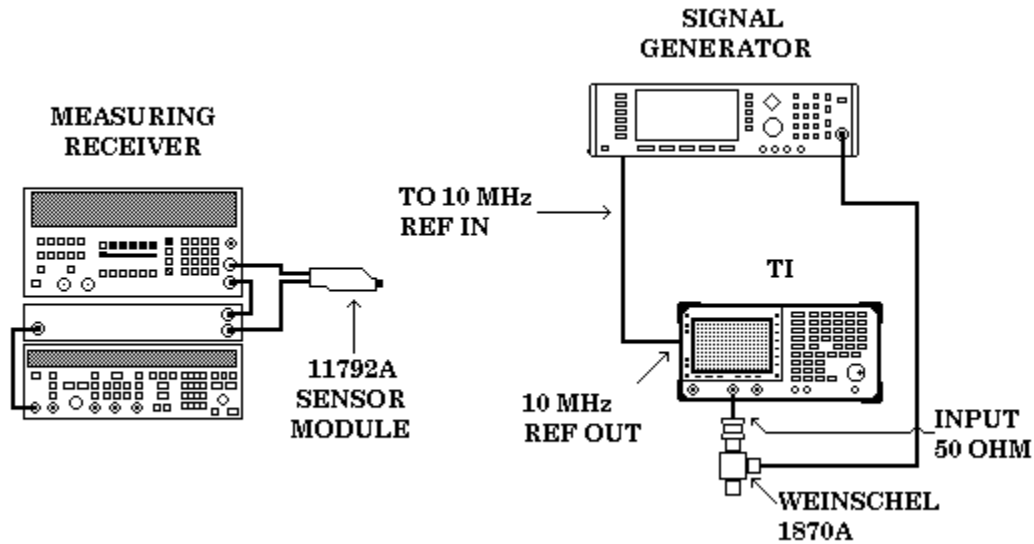

Figure 4. Frequency Response equipment setup.

- (2) Connect 11792A sensor module input to the open end of the power splitter.
- (3) Press TI keys and enter values as listed in (a) through (j) below:
  - (a) **Preset.**
  - (b) **Factory Preset** softkey if it is displayed.
  - (c) **System, [Alignments], [Auto Align], [Off].**
  - (d) **Sweep, [Points 401].**
  - (e) **FREQUENCY, 50, [MHz].**
  - (f) **SPAN, 20, [kHz].**
  - (g) **AMPLITUDE, [Ref Level], 5, [-dBm].**
  - (h) **[Attenuation], 10, [dB] (Man).**
  - (i) **[Scale/Div], 1, [dB].**
  - (i) **BW/Avg, [Resolution BW], 3, [kHz] (Man).**
  - (j) **BW/Avg, [Video BW], 3, [kHz] (Man).**
- (4) Set signal generator frequency to 50 MHz and level output to -5 dBm.
- (5) Setup measuring receiver to measure power in dBm at 50 MHz.
- (6) Press TI **Single** key.
- (7) Press TI **Peak Search** (or **Search**) key.
- (8) Adjust signal generator power level for a measuring receiver indication of -10 +/- 0.05 dBm.
- (9) Record TI **Mkr1** indication.
- (10) Set signal generator to 18 GHz.

- (11) Press TI **FREQUENCY**, **18**, [**GHz**] keys.
- (12) Press TI **Single** key.
- (13) Press TI **Peak Search** (or **Search**) key.
- (14) Adjust signal generator power level for a measuring receiver indication of -10 +/- 0.05 dBm.
- (15) TI **Mkr1** indication will be within +/- 3.3 dB of the indication recorded in (9) above.
- (16) Repeat (9) through (15) above for the remaining signal generator frequency and TI **FREQUENCY** settings listed in table 19.

Table 19. Frequency Response > 10 MHz

Signal generator frequency and test instrument <b>FREQUENCY</b> settings	
17.5	GHz
17.0	GHz
16.5	GHz
16.0	GHz
15.5	GHz
15.0	GHz
14.5	GHz
14.0	GHz
13.5	GHz
13.0	GHz
12.5	GHz
12.0	GHz
11.5	GHz
11.0	GHz
10.5	GHz
10.0	GHz
9.5	GHz
9.0	GHz
8.5	GHz
8.0	GHz
7.5	GHz
7.0	GHz
6.5	GHz
6.0	GHz
5.5	GHz
5.0	GHz
4.5	GHz
4.0	GHz
3.5	GHz
3.0	GHz
2.5	GHz
2.0	GHz
1.5	GHz
1.0	GHz
500	MHz

Table 19. Frequency Response > 10 MHz - Continued

Signal generator frequency and test instrument <b>FREQUENCY</b> settings	
100	MHz
50	MHz reference
20	MHz
10	MHz

- (17) Disconnect signal generator from TI.
- (18) Connect TI **10 MHz REF OUT** to synthesizer/level generator **40/N MHz REF INPUT**.
- (19) Connect synthesizer/level generator **OUTPUT 50Ω** to TI **INPUT 50Ω**.
- (20) Press TI **FREQUENCY, 50, [MHz]** keys.
- (21) Press synthesizer/level generator keys to values as listed in (a) through (c) below:
  - (a) **FREQUENCY** to **50 MHz**.
  - (b) **AMPLITUDE** to **-4 dBm**.
  - (c) **AMPTD INCR** to **0.1 dB**.
- (22) Press TI **Peak Search** key.
- (23) Slowly adjust synthesizer/level generator amplitude until TI **Mkr1** indication is as close as possible to the indication recorded in (9) above.
- (24) Set synthesizer/level generator frequency to 5 MHz.
- (25) Press TI **FREQUENCY, 5, [MHz]** keys.
- (26) Press TI **Peak Search** key.
- (27) TI **Mkr1** indication will be within  $\pm 3.3$  dB of indication recorded in (9) above.
- (28) Repeat (24) through (27) above for synthesizer/level generator frequency and TI **FREQUENCY** settings listed in table 20.

Table 20. Frequency Response < 10MHz

Synthesizer/level generator frequency and test instrument <b>FREQUENCY</b> settings	
5	MHz
1	MHz
500	kHz
100	kHz
75	kHz
50	kHz
20	kHz
10	kHz



(29) Set all outputs to minimum and disconnect equipment setup.

**b. Adjustments.** None

## 18. Displayed Average Noise

### a. Performance Check

- (1) Connect TI **AMPTD REF OUT** to **INPUT 50Ω**.
- (2) Press TI keys and enter values as listed in (a) through (m) below:
  - (a) **Preset**.
  - (b) **Factory Preset** softkey if it is displayed.
  - (c) **Sweep, [Points 401]**.
  - (d) **Input/Output (or Input), [Amptd Ref Out] (On)**.
  - (e) **FREQUENCY, 50, [MHz]**.
  - (f) **SPAN, 2, [kHz]**.
  - (g) **AMPLITUDE, 20, [-dBm]**.
  - (h) **AMPLITUDE, [Attenuation], 10, [dB]**.
  - (i) **BW/Avg, [Res BW], 1, [kHz]**.
  - (j) **BW/Avg, [Video BW], 1, [kHz]**.
  - (k) **Det/Demod, [Detector], [Sample], ◀Return**.
  - (l) **Single**.
  - (m) **Peak Search (or Search)**.
- (3) Record the TI **MARKER** Amptd reading as reading 1. (Ref Amptd)
- (4) Press TI keys and enter values as listed in (a) through (f) below:
  - (a) **AMPLITUDE, [Attenuation], 0, [dB]**.
  - (b) **SPAN, 20, [kHz]**.
  - (c) **BW/Avg, [Res BW], 1, [kHz]**.
  - (d) **BW/Avg, [Video BW], 30, [Hz]**.
  - (e) **Single**.
  - (f) **Peak Search (or Search)**.
- (5) Record the TI **MARKER** Amptd reading as reading 2.
- (6) Calculate reference lvl offst by subtracting reading 2 from reading 1. If the calculated reference lvl offst is greater than 0.05 dB or less than -0.05 dB, record as Ref Lvl Offst(1 kHz RBW) value, otherwise, enter 0.
- (7) Press TI keys and enter values as listed in (a) through (f) below:
  - (a) **AMPLITUDE, [Attenuation], 0, [dB]**.
  - (b) **SPAN, 500, [Hz]**.
  - (c) **BW/Avg, [Res BW], 10, [Hz]**.
  - (d) **BW/Avg, [Video BW], 1, [Hz]**.
  - (e) **Single**.

**TB 9-6625-2339-35**

- (f) **Peak Search** (or **Search**).
- (8) Record the TI **MARKER** Amptd reading as reading 3.
- (9) Calculate reference lvl offst by subtracting reading 3 from reading 1. If the calculated reference lvl offst is greater than 0.05 dB or less than -0.05 dB, record as Ref Lvl Offst (10 Hz RBW) value, otherwise, enter 0.
- (10) Press TI keys and enter values as listed in (a) and (b) below:
  - (a) **Input/Output, [Amptd Ref Out]** (Off).
  - (b) **AMPLITUDE, [More], [Ref Lvl Offst]**, (enter reading 2 value).
- (11) Disconnect equipment setup.
- (12) Connect 50  $\Omega$  termination to TI **INPUT 50 $\Omega$** .
- (13) Press TI keys and enter values as listed in (a) through (n) below:
  - (a) **Auto Couple**.
  - (b) **AMPLITUDE, 70, [-dBm]**.
  - (c) **[Attenuation], 0, [dB]**.
  - (d) **AMPLITUDE, [More], [Ref Lvl Offset]** (enter value calculated in (6) above).
  - (e) **BW/Avg, [Res BW], 1, [MHz]**.
  - (f) **BW/Avg, [Video BW], 10, [kHz]**.
  - (g) **FREQUENCY, [Start Freq], 10, [MHz]**.
  - (h) **FREQUENCY, [Stop Freq], 1, [GHz]**.
  - (i) **Sweep, [Sweep]** (Cont).
  - (j) **Sweep, [Sweep Time]** (Auto).
  - (k) **Single**.
  - (l) **View/Trace, [Trace 1], [Clear Write]**.
  - (m) **BW/Avg, [Avg Type], [Video Avg], [Average], 3, Enter**.
  - (n) **Single**.
- (14) Wait until **Vavg 3** is displayed to the left of graticule lines then press TI keys and enter values as listed in (a) through (e) below:
  - (a) **Peak Search**.
  - (b) **BW/Avg, [Average]** (Off).
  - (c) **Marker→, [Marker→CF]**.
  - (d) **Span, 20, [kHz]**.
  - (e) **BW/Avg, [Res BW], 1, [kHz], [Video BW], 30, [Hz]**.
- (15) Press TI **Single** key and wait for sweep completion.
- (16) Press TI **Display** and **[Display Line]** (On) keys.
- (17) Using TI rotary knob, adjust TI display line to center it on average trace noise. TI display line indication will be within limits specified in first row of table 21.
- (18) Press TI **[Display Line]** (Off) key.
- (19) Repeat technique of (13) (e) through (18) above for remaining frequencies listed in table 21. TI display line indication will be within limits specified in table 21.

Table 21. Displayed average noise level (1 kHz RBW)

Test instrument				
Start frequency	Stop frequency	Resolution BW	Video BW	Display line indication
				Max (dBm)
10 MHz	1 GHz	1 kHz	30 Hz	-116
1 GHz	2 GHz	1 kHz	30 Hz	-115
2 GHz	3 GHz	1 kHz	30 Hz	-112
3 GHz	6 GHz	1 kHz	30 Hz	-112
6 GHz	12 GHz	1 kHz	30 Hz	-110
12 GHz	18 GHz	1 kHz	30 Hz	-107

(20) Press TI keys and enter values as listed in (a) through (k) below:

- (a) **AMPLITUDE**, [**More**], [**Ref Lvl Offset**] (enter value calculated in (9) above).
- (b) **BW/Avg**, [**Res BW**], **1**, [**MHz**].
- (c) **BW/Avg**, [**Video BW**], **10**, [**kHz**].
- (d) **FREQUENCY**, [**Start Freq**], **10**, [**MHz**].
- (e) **FREQUENCY**, [**Stop Freq**], **1**, [**GHz**].
- (f) **Sweep**, [**Sweep**] (Cont).
- (g) **Sweep**, [**Sweep Time**] (Auto).
- (h) **Single**.
- (i) **View/Trace**, [**Trace 1**], [**Clear Write**].
- (j) **BW/Avg**, [**Avg Type**], [**Video Avg**], [**Average**], **3**, **Enter**.
- (k) **Single**.

(21) Wait until **Vavg 3** is displayed to the left of graticule lines then press TI keys and enter values as listed in (a) through (e) below:

- (a) **Peak Search**.
- (b) **BW/Avg**, [**Average**] (Off).
- (c) **Marker→**, [**Marker→CF**].
- (d) **Span**, **500**, [**Hz**].
- (e) **BW/Avg**, [**Res BW**], **10**, [**Hz**], [**Video BW**], **1**, [**Hz**].

(22) Press TI **Single** key and wait for sweep completion.

(23) Press TI **Display** and [**Display Line**] (On) keys.

(24) Using TI rotary knob, adjust TI display line to center it on average trace noise. TI display line indication will be within limits specified in first row of table 22.

(25) Press TI [**Display Line**] (Off) key.

(26) Repeat technique of (20) (b) through (25) above for remaining frequencies listed in table 22. TI display line indication will be within limits specified in table 22.

Table 22. Displayed average noise level (10 Hz RBW)

Test instrument				
Start frequency	Stop frequency	Resolution BW	Video BW	Display line indication
				Max (dBm)
10 MHz	1 GHz	10 Hz	1 Hz	-135
1 GHz	2 GHz	10 Hz	1 Hz	-134
2 GHz	3 GHz	10 Hz	1 Hz	-131
3 GHz	6 GHz	10 Hz	1 Hz	-131
6 GHz	12 GHz	10 Hz	1 Hz	-129
12 GHz	18 GHz	10 Hz	1 Hz	-126

(27) Press TI keys and enter values as listed in (a) and (b) below:

- (a) **AMPLITUDE**, [**More**], [**Ref Lvl Offst**], **0**, [**dB**].
- (b) **Preset**.

(28) Disconnect equipment setup.

**b. Adjustments.** None

## 19. Residual Responses

### a. Performance Check

- (1) Connect 50 Ω termination to TI **INPUT 50Ω**.
- (2) Press TI keys and enter values as listed in (a) through (j) below:
  - (a) **Preset**.
  - (b) **Factory Preset** softkey if it is displayed.
  - (c) **FREQUENCY**, [**Start Freq**], **150**, [**kHz**].
  - (d) **FREQUENCY**, [**Stop Freq**], **1**, [**MHz**].
  - (e) **AMPLITUDE**, **60**, [**-dBm**].
  - (f) **AMPLITUDE**, [**Attenuation**], **0**, [**dB**].
  - (g) **BW/Avg**, **3**, [**kHz**].
  - (h) **BW/Avg**, [**Video BW**], **1**, [**kHz**].
  - (i) **Display**, [**Display line**] (On), **90**, [**-dBm**].
  - (j) **Single**.
- (3) When sweep is finished, look for any residual responses at or above TI display line.

### NOTE

If a residual is suspected, press TI **Single** key again. A residual response will persist on successive sweeps, but a noise peak will not.

- (4) Press TI keys and enter values as listed in (a) through (f) below:
  - (a) **Preset**.
  - (b) **Factory Preset** softkey if it is displayed.
  - (c) **FREQUENCY**, **5.9**, [**MHz**].
  - (d) **FREQUENCY**, [**CF Step**], **9.9**, [**MHz**].
  - (e) **SPAN**, **10**, [**MHz**].
  - (f) **AMPLITUDE**, **60**, [**-dBm**].

- (g) **AMPLITUDE**, [Attenuation], 0, [dB].
- (h) **BW/Avg**, 10, [kHz].
- (i) **BW/Avg**, [Video BW], 3, [kHz].
- (j) **Display**, [Display Line] (On), 90, [-dBm].

(5) Press TI **Single** key. When sweep is finished, look for any residual responses at or above TI display line.

(6) Press TI **FREQUENCY** and  $\uparrow$  keys.

(7) Repeat technique of (5) and (6) above up to 6.7 GHz. Residuals will not be above TI display line.

(8) Disconnect equipment setup.

**b. Adjustments.** None

**20. Power Supply**

**NOTE**

Do not perform power supply check if all other parameters are within tolerance.

**a. Performance Check**

(1) Press TI power **STANDBY** pushbutton.

(2) Disconnect TI power cord.

(3) Remove TI outer case and inner shield.

(4) Plug TI power supply test board into any available slot, except the slot for the processor board.

(5) Connect TI power cord.

(6) Press TI power **ON** pushbutton.

(7) Observe LED's on power supply test board.

**NOTE**

Power supply test board LED's will be illuminated if voltages are within 10 percent of their specified value.

(8) Connect multimeter to test points as listed in table 23 and verify voltages are within limits specified.

Table 23. Power supply voltages

Test instrument		Multimeter indication (Vdc)	
Test point	Common	Min	Max
TP4 or TP10	TP13 (ACOM)	-15.22	-14.78
TP5 or TP11	TP13 (ACOM)	-5.07	-4.93
TP3 or TP9	TP13 (ACOM)	4.93	5.07
TP2 or TP8	TP12 (DCOM)	5.1	5.3
TP1 or TP7	TP13 (ACOM)	14.78	15.22
TP6	TP13 (ACOM)	26.04	29.96

**TB 9-6625-2339-35**

(9) Connect multimeter to TI probe power connector (fig. 5) and verify voltages are within limits specified in table 24.

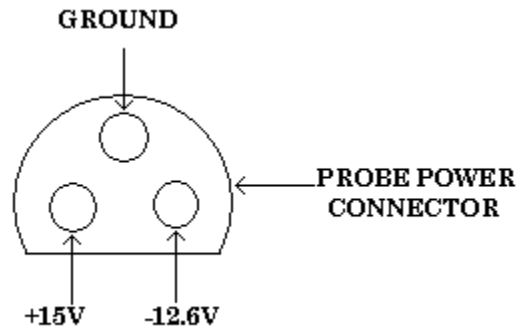

Figure 5. Probe power connector.

Table 24. Probe power connector voltages

Test instrument connector voltage	Multimeter indication (Vdc)	
	Min	Max
-12.6 V	-13.86	-11.3
+15 V	13.95	16.05

- (10) Disconnect equipment setup.
- (11) Press TI power **STANDBY** pushbutton.
- (12) Disconnect TI power cord.
- (13) Reinstall TI inner shield and outer case.
- (14) Connect TI power cord.
- (15) Press TI power **ON** pushbutton.

**b. Adjustments.** None

**21. Final Procedure**

- a.** Deenergize and disconnect all equipment.
- b.** Annotate and affix DA label/form in accordance with TB 750-25.

**By Order of the Secretary of the Army:**

Official:

**PETER J. SCHOOMAKER**  
*General, United States Army*  
*Chief of Staff*



JOEL B. HUDSON  
*Administrative Assistant to the*  
*Secretary of the Army*

0319601

Distribution:

To be distributed in accordance with IDN 344787 requirements for calibration procedure  
TB 9-6625-2339-35.





## INSTRUCTIONS FOR SUBMITTING AN ELECTRONIC 2028

The following format must be used if submitting an electronic 2028. The subject line must be exactly the same and all fields must be included; however, only the following fields are mandatory: 1, 3, 4, 5, 6, 7, 8, 9, 10, 13, 15, 16, 17, and 27.

From: "Whomever" [whomever@redstone.army.mil](mailto:whomever@redstone.army.mil)T  
To: <2028@redstone.army.mil

Subject: DA Form 2028

1. **From:** Joe Smith
2. **Unit:** home
3. **Address:** 4300 Park
4. **City:** Hometown
5. **St:** MO
6. **Zip:** 77777
7. **Date Sent:** 19-OCT -93
8. **Pub no:** 55-2840-229-23
9. **Pub Title:** TM
10. **Publication Date:** 04-JUL-85
11. **Change Number:** 7
12. **Submitter Rank:** MSG
13. **Submitter FName:** Joe
14. **Submitter MName:** T
15. **Submitter LName:** Smith
16. **Submitter Phone:** 123-123-1234
17. **Problem:** 1
18. **Page:** 2
19. **Paragraph:** 3
20. **Line:** 4
21. **NSN:** 5
22. **Reference:** 6
23. **Figure:** 7
24. **Table:** 8
25. **Item:** 9
26. **Total:** 123
27. **Text**

This is the text for the problem below line 27.

